

# ISO-AD32

32-channel 12-bit 200KS/s isolated analog input board



## Functional Description

The ISO-AD32H/L (H for high gain; L for low gain) is a bus-type isolated 12-bit A/D board for PC/AT compatible computers. The isolation inputs can operate up to 500Vrms of common-mode voltage.

The ISO-AD32H/L features a 200KHz 12-bit analog-to-digital converter, on board 1 K bytes FIFO buffer, 32 single-ended or 16 differential analog input channels.

The analog input allows auto-channel /gain scan. This board supports gap-free A/D conversion at 200KHz sampling rates for single channel or 100KHz sampling rates for channel scanning.

The "Hands-Off" design permits all board parameters (channel selection, gain, input type, operating mode) to be performed in software. Once installed, user will never have to worry again.

The innovative design improve several drawbacks of the conventional isolated A/D card. Such as:

1. The speed is faster; up to 200KHz
2. The sampling rate can be programmable
3. On board FIFOs buffer support gap-free A/D conversion and work well under DOS and Windows environment
4. High channel count input can be implemented in half size board.

## Applications

- Data acquisition
- Waveform analysis
- Harsh environment operation
- Signal isolation

- 32 single-ended or 16 differential input channels
- 500VDC photo-isolation protection
- 12-bit resolution
- Maximum 200KHz sampling rate
- Built-in 1K bytes FIFOs
- Single-ended or differential input selectable
- Auto channel scan / gain scan
- Command set programming
- Gap-free A/D conversion

## Specifications

### Analog Input

- Number of channels: 32 single-ended/16 differential
- Resolution: 12-bit
- Conversion rate: 200KS/s max
- Input impedance: 10,000MΩ || 6pF
- Over voltage protection: ±35V
- Accuracy: 0.01% of reading ±1 bit
- Linearity: ±1 bit
- On chip sample & hold
- Zero drift: ±25ppm/ °C of F.S. max

### ISO-AD32H Input Range

Gain	Bipolar(V)	Unipolar(V)	Throughput
0.5	±10	X	125K/s
1	±5	0~10	125K/s
5	±1	X	80K/s
10	±0.5	0~1	80K/s
50	±0.1	X	10K/s
100	±0.05	0~0.1	10K/s
500	±0.01	X	1K/s
1000	±0.005	0~0.01	1K/s

### ISO-AD32L Input Range

Gain	Bipolar(V)	Unipolar(V)	Throughput
0.5	±10	X	200K/s
1	±5	0~10	200K/s
2	±2.5	0~5	200K/s
4	±1.25	0~2.5	200K/s
8	±0.625	0~1.25	200K/s

# ISO-AD32

32-channel 12-bit 200KS/s isolated analog input board

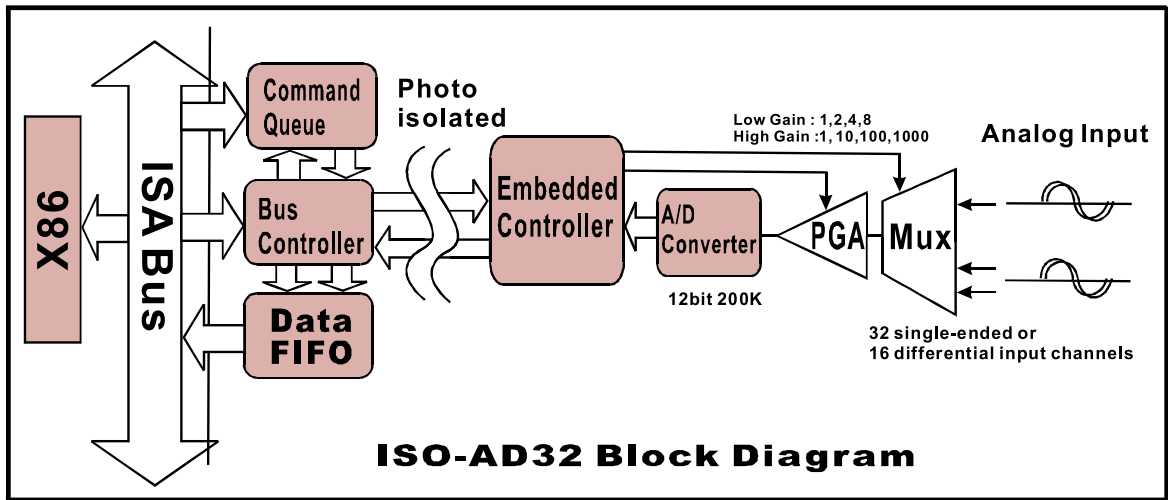

### General Specifications

- I/O connector: one 37-pin D-Sub female
- Power requirements: +5V @ 850 mA
- Operating temperature: 0 ~ 60°C
- Operating humidity: 0 ~ 90% non-condensing
- Storage temperature: -20 ~ 70°C
- Dimensions: 173 mm x 122 mm

### Ordering Information

#### Standard

- ISO-AD32H:** 32-channel 12-bit 200 KHz high gain isolated analog input board
- ISO-AD32H/S:** ISO-AD32H with DN-37
- ISO-AD32L:** 32-channel 12-bit 200 KHz high gain isolated analog input board
- ISO-AD32L/S:** ISO-AD32H with DN-37

#### Optional

- DN-37:** 2x37-pin connector DIN-rail mounting terminal board
- DB-1825:** General screw terminal board
- DB-37:** 37-pin D-sub directly connector terminal board

### Pin Assignment

D.GND	37	19	Ext Trg
A.GND	36	18	+5V
AI 31	35	17	A.COM
AI 30	34	16	AI 15
AI 29	33	15	AI 14
AI 28	32	14	AI 13
AI 27	31	13	AI 12
AI 26	30	12	AI 11
AI 25	29	11	AI 10
AI 24	28	10	AI 9
AI 23	27	9	AI 8
AI 22	26	8	AI 7
AI 21	25	7	AI 6
AI 20	24	6	AI 5
AI 19	23	5	AI 4
AI 18	22	4	AI 3
AI 17	21	3	AI 2
AI 16	20	2	AI 1
		1	AI 0