

ISO-DA8/DA16

14-bit 8/16-channel isolated analog output board



ISO-DA8

ISO-DA16

Functional Description

The ISO-DA8/16 is a bus isolated 14-bit D/A card for PC/AT compatible computers. The optical isolation of the ISO-DA8/16 can operate with up to 2500Vrms of common-mode. The ISO-DA8/16 offers 8/16 channel double-buffered analog outputs. The output range can be configured in different ranges: $\pm 10V$, $\pm 5V$, $0\sim 10V$, $0\sim 5V$ voltage output or 4 to 20 mA or 0 to 20 mA sinkcurrent.

The innovative design improve several drawbacks of the conventional isolated D/A card. For example :

1. Jumperless and trimless
2. The power-on value of analog output can be pre-defined by the user and stored in the on-board EEPROM
3. The calibration is performed under software control, thus eliminating manual trim-pot adjustments. The calibration data is stored in EEPROM. Easy recalibration ensures the accuracy of the board
4. Every channel can be selected as voltage or current output
5. High channel count output can be implemented in half size.

Applications

- Programmable voltage source
- Programmable current sink
- Harsh environment operation
- Process control

Features

- 2500VDC photo-isolation protection
- 8/16-channel, 14-bit analog output
- Unipolar or bipolar outputs available from each converter
- Voltage/Current output from each converter
- Output type and output range can be software programmable
- 4~20 mA or 0~20 mA current sink to ground from each converter
- Double-buffered D/A latches
- Command set programming
- Software Calibration
- 16-channel DI, 16-channel DO

Specifications

Analog Output

- D/A converter: Quad 14-bit MDAC
- Channels: 8/16 independent
- Resolution: 14-bit
- Type: double-buffered, multiplying
- Integral linearity: 0.006% FSR (typical)
- Differential linearity: 0.006 % FSR (typical)

Voltage Output Range

- Unipolar: $0\sim 5V$ or $0\sim 10V$
- Bipolar: $\pm 10V$ or $\pm 5V$
- Current drive: ± 5 mA
- Absolute accuracy: 0.01% FSR (typical)
- Power on state: programmable

Current Output Range

- $0\sim 20$ mA or $4\sim 20$ mA
- Absolute Accuracy: 0.1% FSR (typical)
- Excitation voltage range: + 7V ~ +40V
- Power on state: programmable

Digital I/O

- 16 TTL-level input
- Input low $V_{IL} = 0.8V$ max; $I_{IL} = -0.4$ mA max
- Input high $V_{IH} = 2.0V$ min; $I_{IH} = 20$ μ A max
- 16 TTL-level output
- Output low $V_{OL} = 0.5V$ max; $@I_{OL} = 8$ mA max
- Output high $V_{OH} = 2.7V$ min; $@I_{OH} = 0.4$ mA max

Stability

- Offset temperature coefficient: ± 50 μ V/ $^{\circ}C$
- Gain temperature coefficient: ± 10 ppm/ $^{\circ}C$

ISO-DA8/DA16

14-bit 8/16-channel isolated analog output board

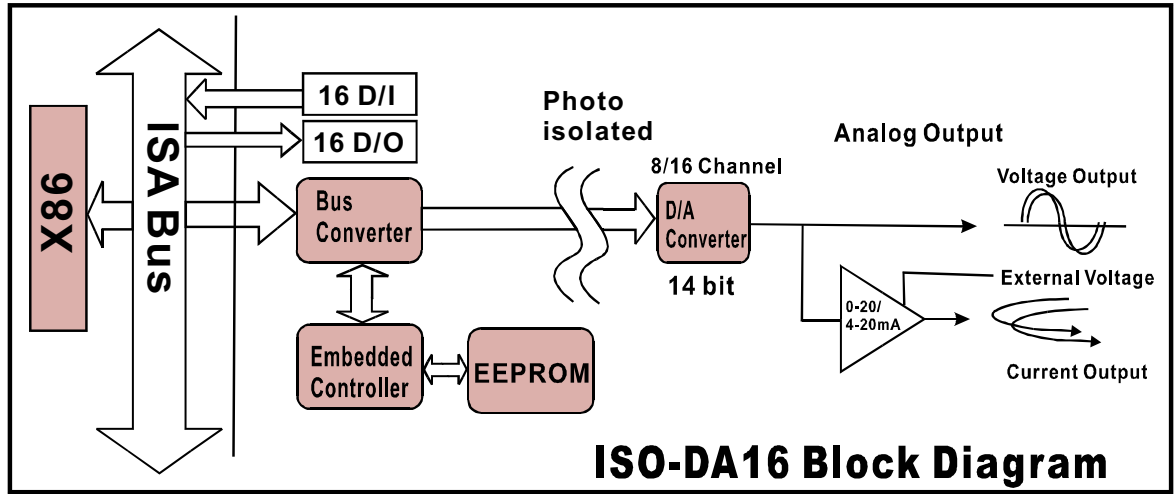

ISO-DA16 Block Diagram

General Specifications

- I/O connector:
 - one 37-pin D-Sub female
 - two 20-pin ribbon male
- Power requirements:
 - ISO-DA8: +5VDC @ 800 mA max
 - ISO-DA16: +5VDC @ 1400 mA max
- Operating temperature: 0 ~ 60°C
- Operating humidity: 0 ~ 90% non-condensing
- Storage temperature: -20 ~ 70°C
- Dimensions: 182 mm x 122 mm

Pin Assignment

CN1				CN2			
DI0	1	2	DI 1	DO0	1	2	DO 1
DI2	3	4	DI 3	DO2	3	4	DO 3
DI4	5	6	DI 5	DO4	5	6	DO 5
DI6	7	8	DI 7	DO6	7	8	DO 7
DI8	9	10	DI 9	DO8	9	10	DO 9
DI10	11	12	DI 11	DO10	11	12	DO 11
DI12	13	14	DI 13	DO12	13	14	DO 13
DI14	15	16	DI 15	DO14	15	16	DO 15
GND	17	18	GND	GND	17	18	GND
+5V	19	20	+12V	+5V	19	20	+12V

CN3

IO_15	37	19	VO_15
IO_14	36	18	VO_14
IO_13	35	17	VO_13
IO_12	34	16	VO_12
IO_11	33	15	A.GND
IO_10	32	14	VO_11
IO_9	31	13	VO_10
IO_8	30	12	VO_9
A.GND	29	11	VO_8
IO_7	28	10	A.GND
IO_6	27	09	VO_7
IO_5	26	08	VO_6
IO_4	25	07	VO_5
A.GND	24	06	VO_4
IO_3	23	05	A.GND
IO_2	22	04	VO_3
IO_1	21	03	VO_2
IO_0	20	02	VO_1
		01	VO_0

Ordering Information

Standard

ISO-DA8: 8-channel 14-bit isolated analog output board

ISO-DA8/S: ISO-DA8 with DN-37

SO-DA16: 16-channel 14-bit isolated analog output board

ISO-DA16/S: ISO-DA16 with DN-37

Optional

DN-37: DIN-rail mounting terminal board

DB-37: Directly connection terminal board

DB-16P: 16-channel OPTO-Isolated digital input board

DB-16R: 16-channel relay output board

DN-20: DIN-rail mounting terminal board

ADP-20/PCI: 20-pin extender